



# Hydraguide™ Hydrostatic Steering System

HGB Service Manual

Service Manual 2752



Hydraulic Pump/Motor Division

# TYPICAL OIL FLOW

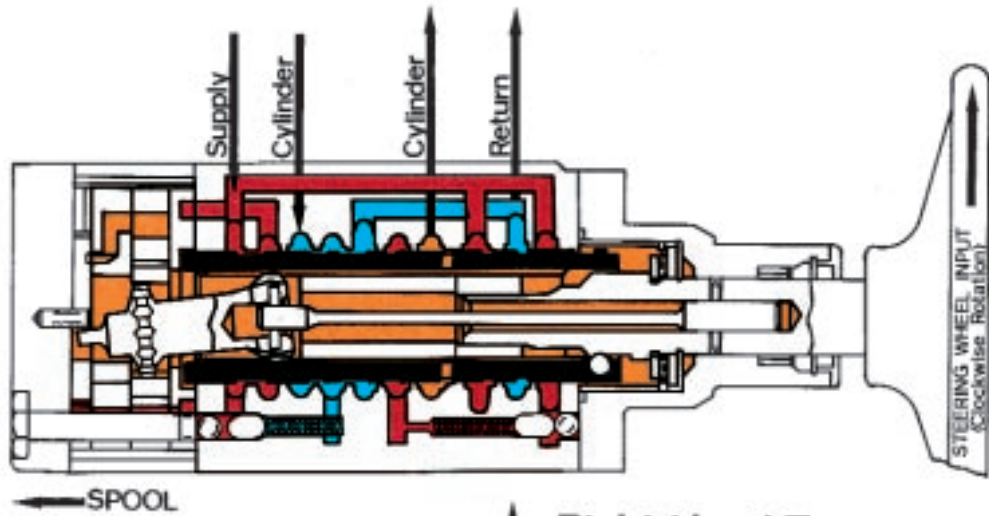

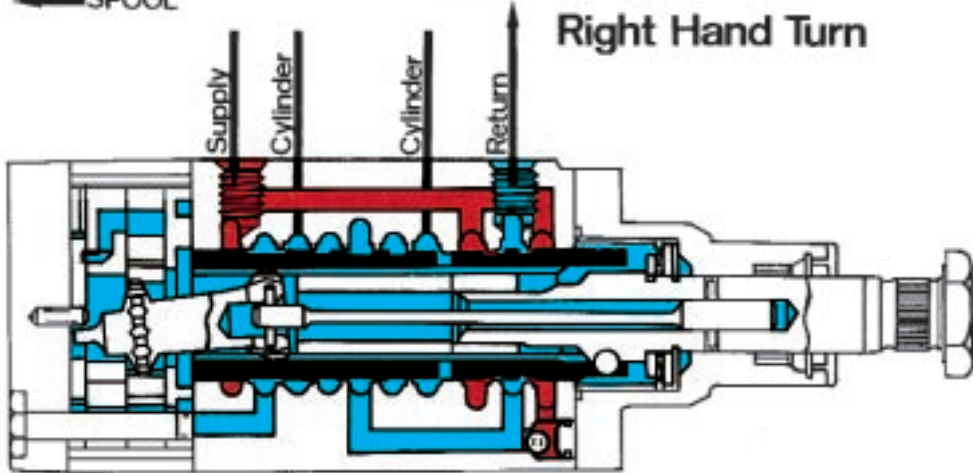

Right Hand Turn

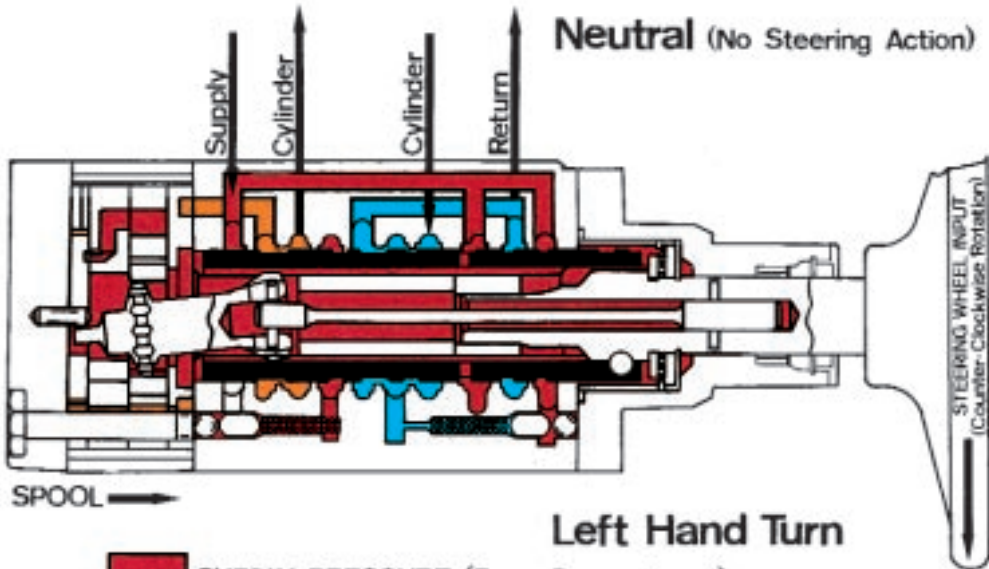

Neutral (No Steering Action)



Left Hand Turn

-  SUPPLY PRESSURE (From Power Pump)
-  RETURN OIL FLOW (To Reservoir)
-  METERED OIL FLOW (To Cylinder)

# Table of Contents

## Section I

System Operation .....	page 2
Design and Function .....	page 2
Control Valve .....	page 3
Metering Section .....	page 3
Rotor Operation .....	page 3
Power Steering Operation .....	page 4
Manual Steering Operation .....	page 4
Exploded View .....	page 5
Service Parts List .....	page 6
Pressure Dam Check Installation .....	page 7

## Section II

Service Procedure .....	page 8
Work Conditions .....	page 8
Seal Replacement Instructions .....	page 8
Servicing of HGB Unit .....	page 8
Disassembly Procedure .....	page 8

## Section III

Inspection and Replacement .....	page 11
----------------------------------	---------

## Section IV

Assembly Procedure .....	page 12
Filling and Air Bleeding System .....	page 15
Hydraulic Fluid .....	page 15
Column Assembly and Disassembly Procedures .....	page 16
Tips for Maintaining the System .....	page 17
Exploded View .....	page 19



## WARNING

**FAILURE OR IMPROPER SELECTION OF IMPROPER USE OF THE PRODUCTS AND/OR SYSTEMS DESCRIBED HEREIN OR RELATED ITEMS CAN CAUSE DEATH, PERSONAL INJURY AND PROPERTY DAMAGE.**

This document and other information from Ross Operation, its subsidiaries and authorized distributors provide product and/or system options for further investigation by users having technical exper-

tise. It is important that you analyze all aspects of your application and review the information concerning the product or system in the current product catalog. Due to the variety of operating conditions and applications for these products or systems, the user, through its own analysis and testing, is solely responsible for making the final selection of the products and systems and assuring that all performance, safety and warning requirements of the application are met.

The products described herein, including without limitation, product features, specifications, designs, availability and pricing, are subject to change by Ross Operation and its subsidiaries at any time without notice.

## HYDRAGUIDE™ STEERING MODEL HGB

For over half a century, Ross has anticipated and met the changing and increasing needs for better steering of automotive, construction, industrial and agricultural machines. This hydrostatic steering system described herein is further evidence of this fact.

**Hydraguide™** is the Ross name given to hydrostatic steering systems. In the HGB type **Hydraguide™** steering system, an engine-driven pump, relief valve, or cylinder, reservoir, filter, fluid lines, and an HGB control unit are needed. An automotive type steering wheel is attached to the HGB unit and the power cylinder is connected by suitable means to the steered wheels.

The driver has power steering control at all times, so long as system components work together, system integrity is maintained, and adequate fluid is present. If there is a failure in the high-pressure circuit, a loss of power steering will result. The HGB, however, is designed to have some manual steering capability, depending on the installation. If you can't manually steer the vehicle without using extraordinary measures, such as leaving your seat, or pushing with your legs, don't try it. Repair the failure in the power circuit. Some vehicles may be impossible to steer manually because of their weight and size.

**WARNING:** EXTRAORDINARY MEASURES SHOULD NOT BE USED IN ATTEMPTING TO MANUALLY STEER THE VEHICLE, AS THEY MAY GENERATE FORCES IN EXCESS OF 125 FT. LBS., THEREBY DAMAGING THE UNIT INTERNALLY, WHICH COULD RESULT IN A COMPLETE LOSS OF STEERING.

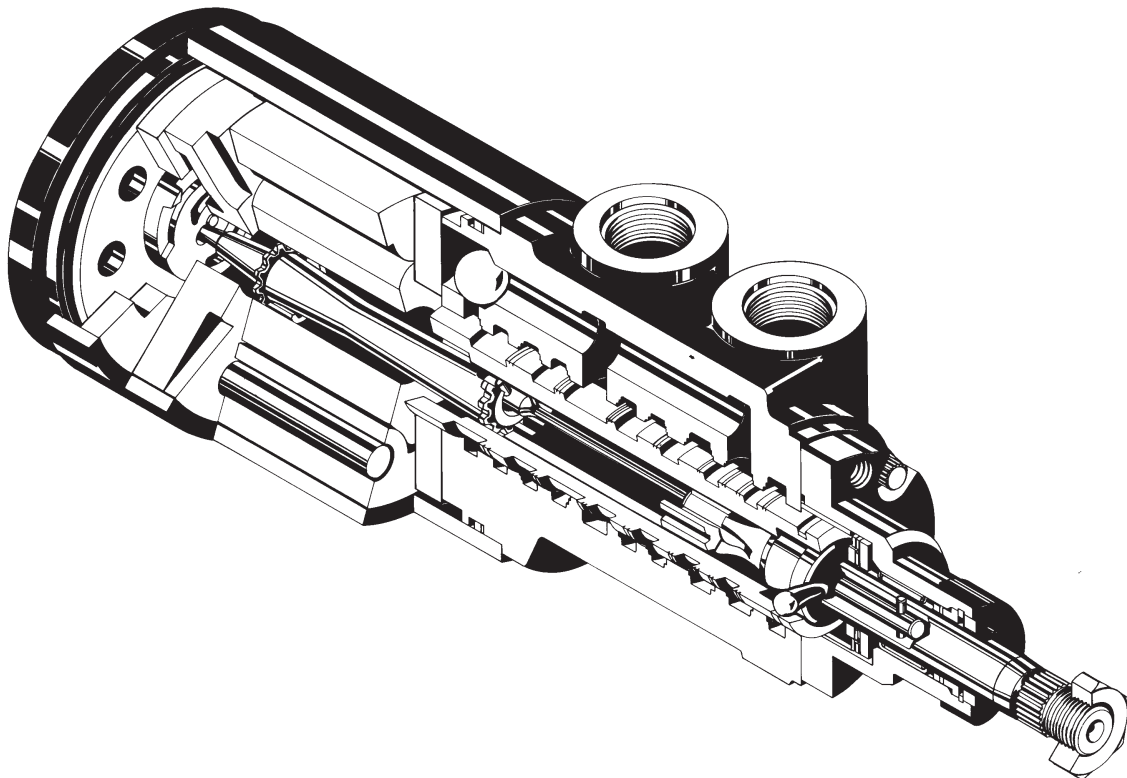

**WARNING:** ALL STEERING MECHANISMS ARE LIFE AND LIMB ITEMS. AS SUCH, IT IS IMPERATIVE THAT THE INSTRUCTIONS IN THIS BOOKLET ARE FOLLOWED TO THE LETTER. FAILURE TO OBSERVE THE PROCEDURES SET OUT IN THIS PAMPHLET MAY RESULT IN LOSS OF STEERING.

## SECTION I

### A. SYSTEM OPERATION

This literature with the illustrations shown covers a standard basic design of the HGB unit. Variations may be engineered to suit special requirements.

The description of the operation of the HGB unit and the illustrations explain the functioning of the system for the utilization of the hydraulic power generated by the engine-driven pump for power steering.

Satisfactory performance of this system requires a **well engineered installation designed for the particular type of vehicle and the type and kind of service for which it will be used.** Ross Engineering advice and assistance is available and we welcome requests.

Information on the required engine-driven pump capacity and the power cylinder size and connecting lines are provided through engineering contacts. A balanced cylinder design is preferred.

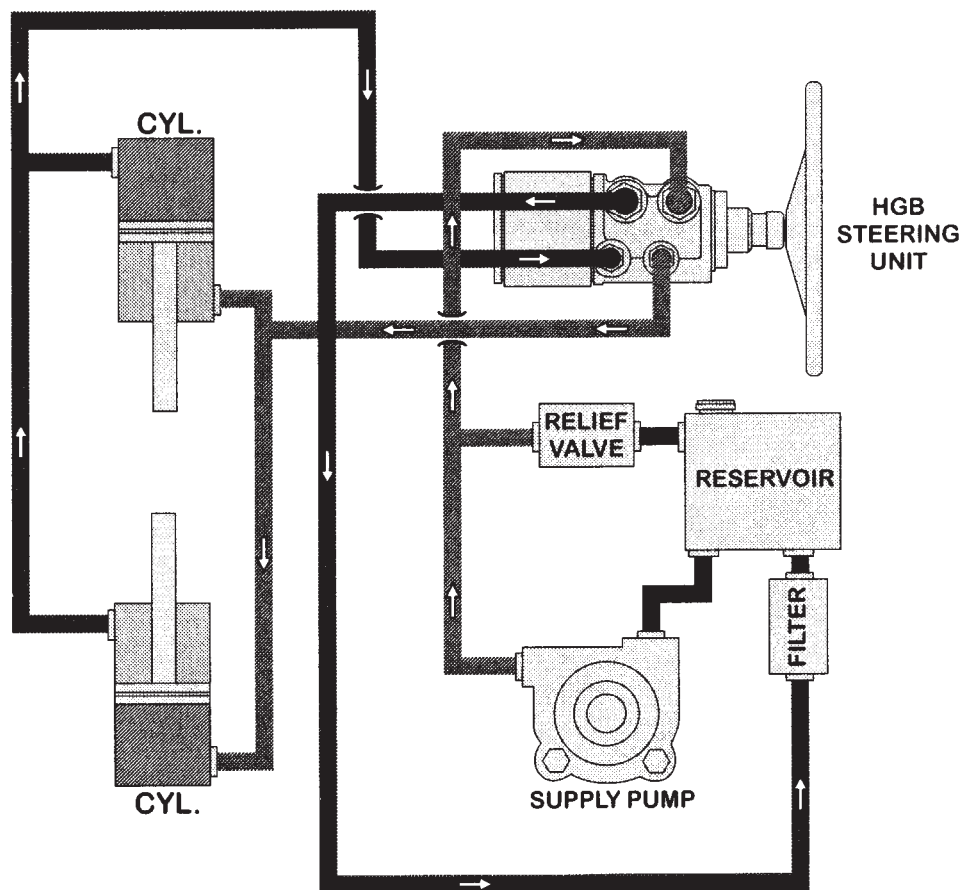

Figure HGB-1

### B. DESIGN & FUNCTION

The HGB unit consists of a fluid control valve section

and a fluid metering section which are hydraulically and mechanically inter-connected.



**C. CONTROL VALVE**

The control valve section contains a mechanically actuated linear spool which is torsion bar centered.

The function of the control valve section is to direct the fluid to and from the metering section, to and from the cylinder, and to regulate the pressure supplied to the cylinder. The valve is provided with unique pressure chambers which insure effective circuit isolation.

**D. METERING SECTION**

The metering section consists of a commutator and bi-directional gerotor element, which contains an orbiting rotor and a fixed stator. The commutator rotates at orbit speed with the rotor and channels the fluid to and from the rotor set and the valve section.

The function of the metering section is to meter the oil to the cylinder, maintaining the relationship between the hand wheel and the steered wheels.

**E. ROTOR OPERATION IN THE METERING ELEMENT (See Fig. HGB-3)**

Each lobe of the rotor has a diametrically opposite lobe, therefore, when one lobe is in a cavity its opposite lobe is at the crest of the stator's convex form opposite the cavity. As the rotor is rotated, each lobe in sequence is moved out of its cavity to the crest of the stator's convex form and this forces each opposite lobe, in sequence, into a cavity. Due to the interaction between the rotor and the stator, there are 42 fluid discharging actions in one revolution of the rotor. When the rotor is moving, fluid is always flowing out of three of the cavities while fluid is flowing

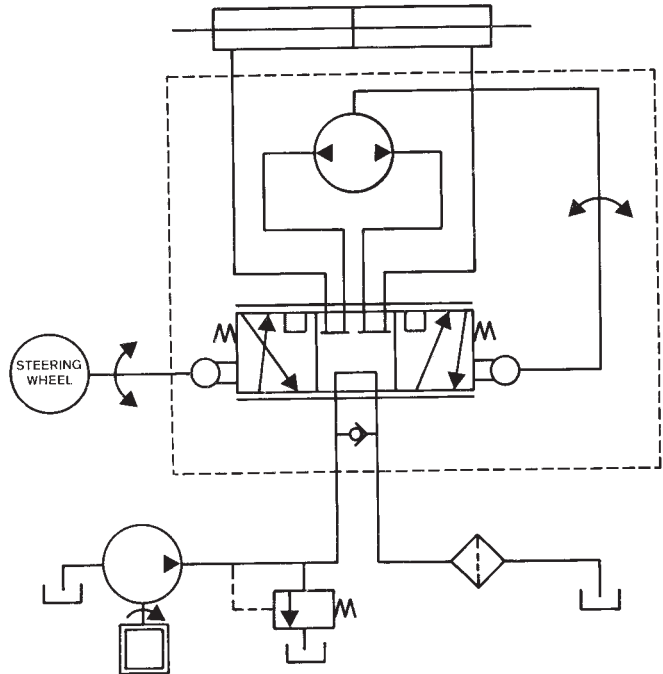

Figure HGB-2

into three other cavities, and one of the cavities is inactive as it changes from one of discharging fluid to one of admitting fluid. The commutator rotates with the rotor and channels the fluid from and to the valve section, and to and from the metering element.

**METERING ELEMENT**

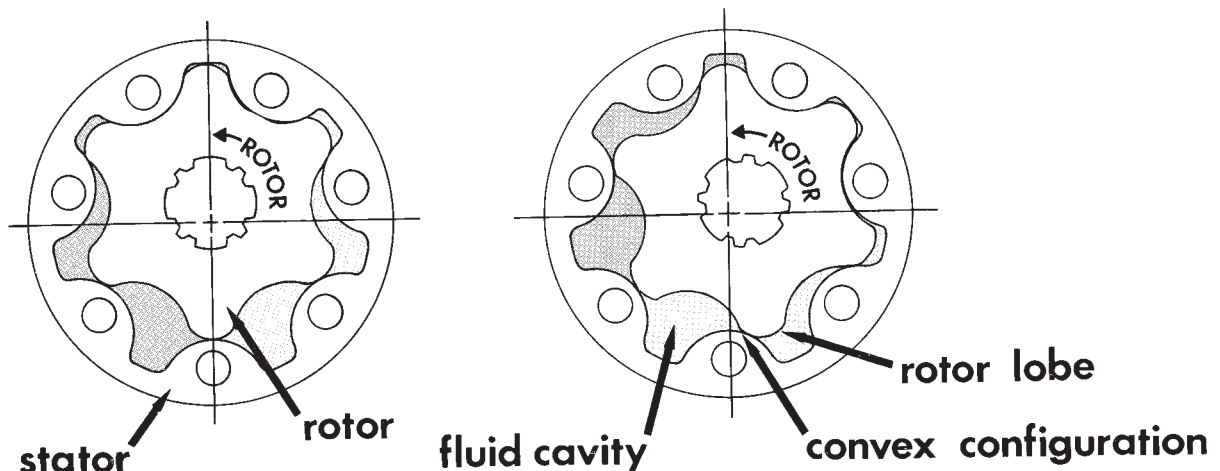

Figure HGB-3

## F. POWER STEERING OPERATION

When the spool is in center or neutral position, the hydraulic oil from the engine-driven pump circulates through the valve section, directly back to the reservoir with sufficient pressure only to overcome friction of valve channels and lines. There is no circulation of engine-driven pump oil to or from the cylinder. Note the center diagram showing neutral position (Reference the typical oil flow diagram on the back of the front cover) on which no directional arrows appear in the metering channels. The oil pressure at the two cylinder ports is equal and produces ineffective forces in the cylinder.

In order to accomplish a power steering maneuver, the operator must rotate the steering wheel in the direction of the steering maneuver. The initial rotation of the steering wheel rotates the input shaft which tends to rotate the drive link and rotor set through the torsion bar centering spring. Rotation of the rotor set and spool which are coupled by the drive link, is resisted by the cylinder pressure required to overcome the steering forces. As the input shaft is rotated relative to the spool, the centering spring is torsionally deflected. Axial shift of the spool is inducted by the ball which is captive in the spool and engaged in the helical groove provided in the input shaft.

When the spool is axially displaced within the body, fluid channels are selected connecting the engine-driven pump to the intake side of the rotor set via the

commutator. The exhaust side of the rotor set is connected, through the commutator, to one side of the cylinder while the other side of the cylinder is connected to the reservoir. (See Figures HGB-1 and 2).

Further axial displacement of the spool results in increased system pressure to provide the level of pressure required. A portion or all of the hydraulic fluid at the required pressure from the engine-driven pump, depending upon the speed of steering, is directed to the cylinder via the metering section, using cylinder movement to accomplish the steering maneuver.

## G. MANUAL STEERING OPERATION

In the absence of system pressure, the driver's manual effort displaces the spool axially. When the spool is displaced within the body, fluid channels are selected connecting the rotor set, which is now acting as a pump, via the commutator to one side of the cylinder. The return flow from the other side of the cylinder is channeled through a recirculation valve so that the oil will flow to the intake side of the rotor set via the commutator instead of back to the reservoir. (See. Figure HGB-5) The recirculation valve is a ball check valve in a channel connecting the return flow chamber to the engine-driven pump pressure inlet chamber. The recirculation valve is closed during power operation.

**WARNING:** EXTRAORDINARY MEASURES SHOULD NOT BE USED IN ATTEMPTING TO MANUALLY STEER THE VEHICLE, AS THEY MAY GENERATE FORCES IN EXCESS OF 125 FT. LBS., THEREBY DAMAGING THE UNIT INTERNALLY, WHICH COULD RESULT IN A COMPLETE LOSS OF STEERING.

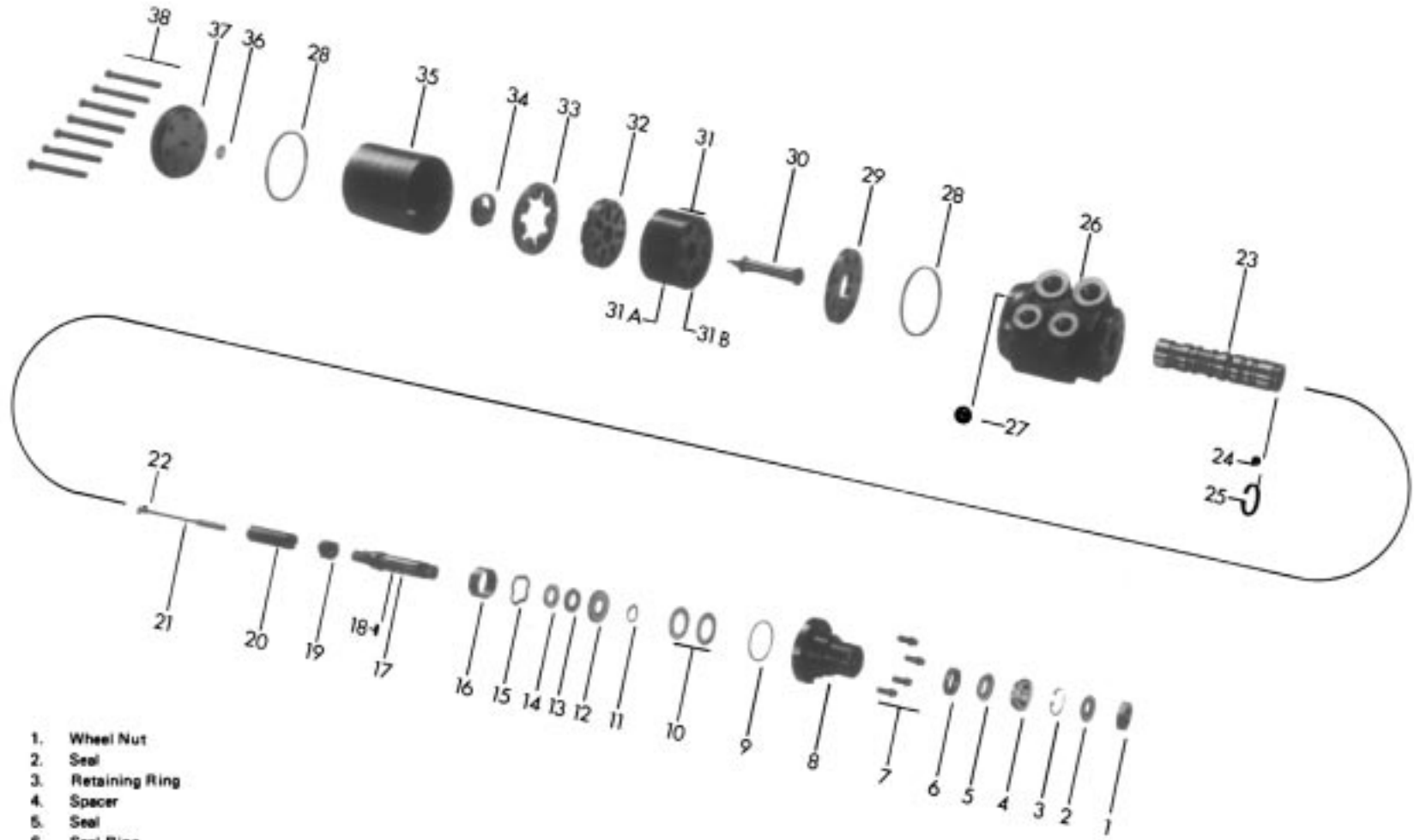

- |                            |                       |                              |
|----------------------------|-----------------------|------------------------------|
| 1. Wheel Nut               | 19. Drive Ring        | 30. Drive Link               |
| 2. Seal                    | 20. Spacer            | 31. Rotor Set                |
| 3. Retaining Ring          | 21. Torsion Bar       | 31A. Stator                  |
| 4. Spacer                  | 22. Needle Roller     | 31B. Rotor                   |
| 5. Seal                    | 23. Valve Spool       | 32. Manifold                 |
| 6. Seal Ring               | 24. Ball (5/16 Dia.)  | 33. Commutator Ring          |
| 7. Screw (5/16-18-3/4) (4) | 25. Spring            | 34. Commutator               |
| 8. Upper Cover             | 26. Housing           | 35. Sleeve                   |
| 9. Seal                    | 27. Ball (13/16 Dia.) | 36. Washer                   |
| 10. Shims                  | 28. Seal (2)          | 37. End Cover Assembly       |
| 11. Retaining Ring         | 29. Wear Plate        | 38. Screw (3/8-24-3 7/8) (7) |
| 12. Thrust Washer          |                       |                              |
| 13. Thrust Bearing         |                       |                              |
| 14. Thrust Washer          |                       |                              |
| 15. Wave Washer            |                       |                              |
| 16. Spacer                 |                       |                              |
| 17. Input Shaft            |                       |                              |
| 18. Needle Roller          |                       |                              |



**USE WITH HGB SERVICE MANUAL EXPLODED VIEW**

1 Wheel Nut	2, 4, 5, & 6 Seal Kit	3 Snap Ring	7 Screw (4 ea.)	8 Upper Cover	9 Seal	10 Shim Kit	11 Snap Ring	12 Thrust Washer	
026045	HG500007	401233	020206	HGA016005X1	032840X1	033157-X2	401367	400100	
13 Thrust Bearing	14 Thrust Washer	15 Wave Washer	16 Spacer	17 Pin Whole Shaft	Or 17 Wheel Moun Shaft	Or 17 Full Bolt Groove Shaft	18 Needle Roller	19 Drive Ring	24 Ball 5/16" dia.
063979	400075	401366	477277	089181	089180	089193	040114	HGB013006	400013
25 Springs	27 Ball 13/16 dia.	28 Seal (2 ea.)	29 Wear Plate	32 Manifold	33 & 34 Commutator & Ring	36 & 37 End Cover Assy.			
401412	400107	032519	477251	HGB015000	HGB014000-A1	402392-X1			

**STANDARD PARTS THAT CHANGE WITH DISPLACEMENT**

Series	20 Spacer	21 & 22 Torsion Bar*	30 Drive Link	31 Rotor Set	35 Sleeve	38 Bolts (7 ea.)
HGB 16	477252-177	BASE-A1-500	HGB013001	HGB167001	099044	021400
HGB 24	477252-227	BASE-A1-550	HGB013001	HGB247001	099045	021401
HGB 32	477252-227	BASE-A1-600	HGB013001	HGB327001	099046	021402
HGB 40	477252-327	BASE-A1-650	HGB013001	HGB407001	099043	021403
HGB 48	477252-177	BASE-A1-500	HGB013002	HGB487000	099054	021404
HGB 64	477252-277	BASE-A1-600	HGB013007	HGB647001	099062	021320

23 & 26 Spool and housing are non-serviceable due to select fit. If either needs replaced entire hydraguide must be replaced.

\* Torsion bars are unit specific. To select the correct replacement, measure the diameter of the center section of the bar and the length between holes, then select the correct base number from the following chart:

Base Number	Bar Center Diameter - in.	Length Between Holes - in.
401360	0.147	5.00 - 5.62
401363	0.160	6.00 - 6.50
401368	0.160	5.00 - 5.62
401413	0.154	5.00 - 5.62
401432	0.147	6.00 - 6.50
401435	0.139	5.00 - 5.62
401627	0.139	6.00

# PRESSURE DAM CHECK INSTALLATION

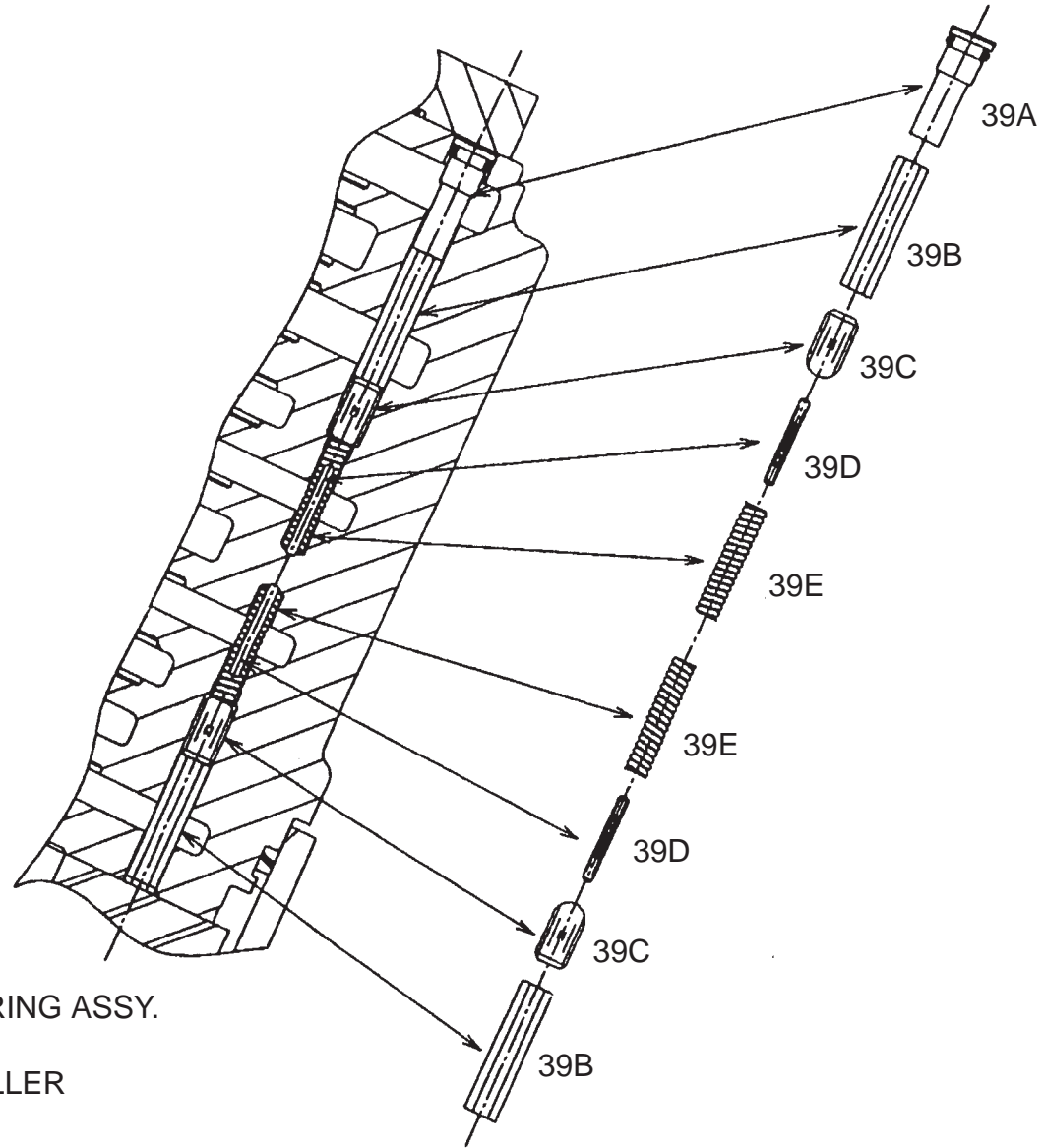

- 39A - 036183-A1 (1) PLUG & "O" RING ASSY.
- 39B - 040138 (2) HEX ROD
- 39C - 040113 (2) NEEDLE ROLLER
- 39D - 040139 (2) ROD
- 39E - 401411 (2) SPRING

## SECTION II

### SERVICE PROCEDURE

For service information on the steering pump (engine-driven) and cylinder, see information provided by the manufacturer of these units.

For servicing the HGB unit and the system, see information and instructions in the following sections.

Servicing of HGB Unit	Page 8
Filling and Air Bleeding the System When Drained of Oil	Page 16
Hydraulic Fluid	Page 16

### CLEAN WORK CONDITIONS

It is a must that the system be kept free of dirt or foreign matter in the oil circuit. Cleanliness in servicing this power steering system is absolutely necessary.

If it is necessary to disassemble any of the units, make sure that a clean work bench or table is used. (A piece of clean wrapping paper makes an excellent disposable top).

Outside dirt should be cleaned off before disconnecting lines and port holes should be plugged immediately after disconnecting lines.

Finish cleaning off outside dirt before placing on work bench.

When disassembled, parts should be cleaned only in clear-clean petroleum base solvent and blown dry with clean, dry air. Other solvents may cause deterioration of rubber seals. Avoid wiping parts with cloth and never steam clean hydraulic steering assemblies.

**WARNING:** SINCE SOLVENTS ARE FLAMMABLE, BE EXTREMELY CAREFUL WHEN USING THEM. EVEN A SMALL EXPLOSION OR FIRE COULD CAUSE DEATH OR INJURY.

**WARNING:** EYE PROTECTION SHOULD BE WORN.

**WARNING:** OSHA MAXIMUM AIR PRESSURE REQUIREMENTS SHOULD BE COMPLIED WITH TO PREVENT INJURY.

### SEAL REPLACEMENT INSTRUCTIONS

For numerous installation you may want to purchase the J26910 tool kit available from KENT MOORE TOOL DIVISION, 29784 Little Mack, Roseville, Michigan 48066 - Phone 800-345-2233.

**Caution:** Follow the Instruction and do not disassemble The Hydraguide unit upper cover (8) to replace the shaft seal (5).

1. Remove the steering wheel nut (1), steering wheel and steering wheel column, if applicable. Refer to page 17 for instruction on removal of the steering column.
2. Remove the dirt seal (2) over the end of the Hydraguide unit upper cover, if applicable. Discard this part.
3. Remove the retaining ring (3), do not discard, this part must be reinstalled during assembly procedure.
4. Remove the seal package parts (4) (5) + (6) from the Hydraguide unit by one of the following methods:
  - a) If the Hydraguide unit has not been removed from the vehicle, rotate the Hydraguide unit input shaft either clockwise or counter clockwise to pressurize the system and force the seal package out. Discard these parts.
  - b) If the Hydraguide unit has been removed from the vehicle plug three of the four ports in the Hydraguide unit and pressurize the other port with air pressure to force the seal package out. Discard these parts.

5. **Note:** Clean the Hydraguide unit input shaft (17) and upper cover (8) seal bore to remove particles of dirt, felt, lint, etc. with a clean, lint-free rag. **Caution:** excessive particles of felt or lint can cause the new seal package to leak.
6. Cover the end of the Hydraguide unit input shaft with cellophane tape to protect the new seal (5) when it is assembled over the sharp edges of the input shaft.
7. Lubricate the new seal using hydraulic oil and install the new seal (5) with lip side first, onto the Hydraguide unit input shaft.
8. Remove the cellophane tape from the Hydraguide unit input shaft.
9. Assemble the new washer (4), with small end first, onto the Hydraguide unit input shaft and push the new washer and the new seal (5), previously installed, down into the Hydraguide unit upper cover. (A short piece of metal tubing 15/16 minimum I.D. x 1-3/16 maximum O.D. or a 7/8 deep well socket may be used to push these parts into place.)
10. Assemble the previously used retaining ring (3) onto the Hydraguide unit input shaft and down into the Hydraguide unit upper cover groove. Be sure the rounded edge of the retaining ring (3) is faced inward.
11. Assemble the new seal (2) onto the Hydraguide unit input shaft and down into the Hydraguide unit upper cover (8) counter bore.
12. Assemble the steering column, if applicable.
13. Assemble the steering wheel and wheel nut, torque the wheel nut to 35 ft. lbs.

## SERVICING OF HGB UNIT

Refer to exploded view, Figure HGB-6 for parts identification. The valve spool (23) and the housing (26), the commutator (34), and commutator ring (33), as well as the rotor (31B) and the stator (31A) are not separately replaceable because they are selectively fitted at the factory. If the valve spool or housing need replacement, the complete housing assembly must be replaced. If the commutator or the commutator ring need replacement, both must be replaced as a matched set. If the rotor or stator need replacement, the complete rotor set (31) must be replaced. The pin in the end cover assembly (37) is not separately replaceable. If the pin or end cover need replacement, the end cover assembly (37) must be replaced.

**NOTE: The upper cover screws (7) and end cover screws (38) are special screws and must be replaced with the same type if they need replacement.**

## DISSASSEMBLY PROCEDURE

Plug the four port holes and clean the exterior of the unit thoroughly. Then remove the plugs.

1. To prevent possible distortion or damage to unit if placed directly in vise, the following procedure should be used. Insert an "o" ring tube fitting, with tube nut or fitting cap attached, into one of the four threaded ports in the housing. Clamp the fitting in a vise in a manner which will locate the seven end cover screws (38) in an upright position. (See Figure HGB-6).

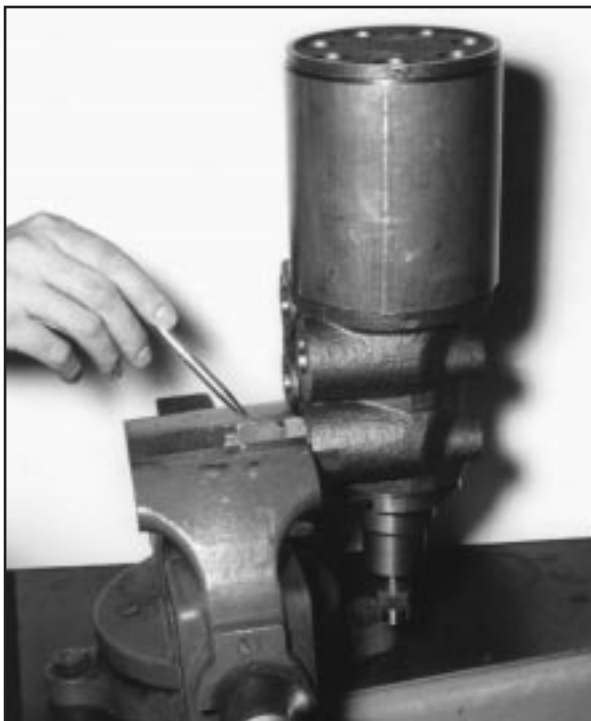

Figure HGB-6

2. Remove the seven end cover screws (38) from the end cover assembly (37).

**NOTE: Special care should be used in the following steps to insure protection of the ground and lapped faces of the components. Avoid scratching or nicking of finished surfaces.**

3. Remove end cover assembly (37) by inserting screw driver between end cover assembly (37) and sleeve (35). Pry up end cover assembly and lift from unit. Inspect seven end cover assembly holes for damage around edge of holes. If there is evidence of damage, replace end cover assembly. Remove and discard seal (28).

**CAUTION: The washer (36) and commutator (34) may adhere to the end cover assembly by oil film and may be removed with the end cover assembly. Do not attempt to remove pin in end cover because pin is press fit and is non-serviceable.**

4. Remove the commutator ring (33) and manifold (32) by using two of the end cover screws (38) as a lifting tool. (See Figure HGB-7). If the washer (36) and commutator (34) did not adhere to the end cover assembly, they should be lifted out with commutator ring (33) and manifold (32).



Figure HGB-7

5. Remove rotor set (31) and wear plate (29) by using two of the end cover screws (38) as a lifting tool. (Similar to Figure HGB-7).

6. Remove sleeve (35) by inserting screw driver between sleeve (35) and housing (26) and pry up.
7. Remove drive link (30).
8. Remove seal (28) and discard.
9. Remove 13/16" dia. steel ball (27). (See Figure HGB-8). Remove pressure dam components; items 39B, 39C, 39D and 39E. Refer to page 7 for details.



Figure HGB-8

10. Reverse the HGB unit in the vise to place the input shaft (17) in a vertical position. Using a center punch, mark the upper cover flange (8) in relation to a similar mark placed on the port face of the housing (26) to facilitate reassembly. (See Figure HGB-9).
11. Remove the four upper cover screws (7) by using a 5/16-12 point socket.
12. Grasp the input shaft (17) and with a smooth upward motion, remove the input shaft (17), upper cover (8) and valve spool (23) from the housing (26).
 

**NOTE: Avoid applying side forces to the valve spool which would cause binding of the closely fitted assembly. Never use excessive force to remove the valve spool from the housing.**
13. Remove and discard seal (9).
14. Remove the upper cover (8) with shaft seal package (items 2 thru 6) intact. Remove spacer item (16).
15. Remove shims (10) from either upper cover (8) cavity or from face of thrust washer (12). Count and record the number of shims to aid in reassembly of the unit.



Figure HGB-9

16. Remove seal (2), retaining ring (3), spacer (4), seal (5) and seal ring (6) from upper cover (8). Discard seal (2), spacer (4), Seal (5) and Seal ring (6).

**NOTE: Retaining ring pliers should be used to remove retaining ring (3).**

**NOTE: Seal (5) and seal ring (6) may be bonded together as a single unit.**

17. Remove the retaining ring (11), thrust washer (12), thrust bearing (13), thrust washer (14) and wave washer (15) from input shaft (17).
18. Remove the needle roller (18) by using a pin punch of .120 max. diameter for a minimum of .625 length. The input shaft (17) should be placed on a block of wood (to avoid shaft damage) and the needle roller removed by impact using light hammer blows. (See Figure HGB-10).



Figure HGB-10

19. Remove the torsion bar (21) and spacer (20) by inverting the valve spool assembly and allowing the parts to fall free. Do not remove needle roller (22) from torsion bar. (See Figure HGB-11).



Figure HGB-11

20. Remove the drive ring (19) by placing the end of valve spool (23) on the surface and rotate input shaft (17) to extremes of travel until drive ring (19) falls free. (See Figure HGB-12).
21. With the valve spool assembly in the same position as the step above, rotate the input shaft (17) in a clockwise direction until the 5/16" dia. steel ball (24) disengages from the helical groove in the input shaft. Lift out input shaft.

**CAUTION: The 5/16" dia. steel ball may fall free and care should be used to not lose it.**



Figure HGB-12

22. **Do not remove ball retaining spring (25) unless replacement is required.** If necessary to remove this ball retaining spring, grasp the end with pliers and lift over the shoulder on valve spool (23). Continue with a pulling motion to progressively remove the ball retaining spring. A screw driver may be used to assist in the prying of the spring over the shoulder of the valve spool. Care must be used to avoid scratching or nicking of the valve spool outside diameter and control edges. Discard the retainer (25) if removed.

This completes disassembly of the HGB unit.



## Section III

### INSPECTION AND REPLACEMENT

Visually inspect all parts and replace those parts not in good condition. The following finished surfaces should be inspected for abnormal wear, scoring or damage.

1. Housing (26) bore and ends.
2. Valve spool (23) outside diameter. Some bur-nishing due to use may be observed.
3. Valve spool (23) control edges.
4. Valve spool (23) splines.
5. Input shaft (17) seal area. Check for rust, pitting and excessive wear. Light circumferential pol-ishing due to seal contact may be observed.
6. Input shaft (17) helical groove. Note the contact pattern created by the actuator ball (24). Surface should be free from pits, chipping or surface break down.
7. Thrust bearing (13) and thrust washers (12 and 14). Inspect for pitting of rolls and faces of thrust washers.
8. Drive link (30) pin slot. Width of slot must not exceed .001 inch difference at any point in its length.
9. Drive link (30) teeth.
10. Torsion bar (21) and needle roller (22). Difference in diameter of needle roller (22) should not exceed .001.

The following parts may show a polish pattern due to the rotor action and the circular motion of the com-mutator. The mating surfaces of these components are ground and lapped and should be free from nicks, burrs and scoring.

1. Wear Plate (29).
2. Manifold (32).
3. Rotor Set (31).
4. Commutator (34) and commutator ring (33).

**Note: Thickness difference between com-mutator and commutator ring (33) shall not exceed .0025 inch.**

5. End cover assembly (37).

**NOTE: Rotor set (31) requires special atten-tion in handling to avoid nicks and scratch-ing and it is recommended that the rotor (31B), stator (31A) be checked in the assem-bled condition. To inspect the rotor set, place the assembly, face down, on the lapped face of the end cover assembly (37)**

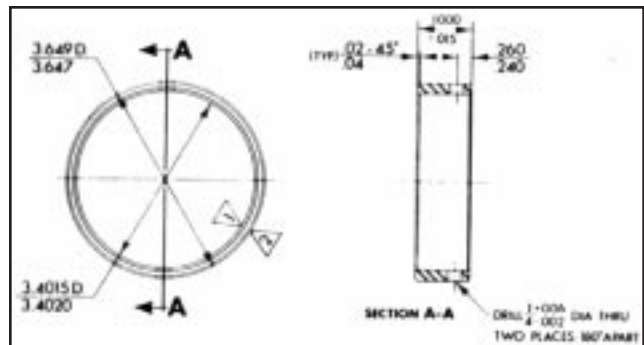

Pilot Ring Tool  
Figure HGB-13

**and check for freedom of rotor rotation with-in the stator.**

Carefully lift rotor set (31) from the end cover assembly (37) and measure the thickness of the rotor (31B) and stator (31A). Thickness dif-ference between rotor and stator shall not exceed .007 inch.

Using a feeler gage, check the rotor (31B) to stator (31A) clearance as shown in figure HGB-14. If there is more than a .007 inch clearance, rotor set (31) must be replaced. (See Figure HGB-14).

**NOTE: If the rotor set is four inches thick, the maximum allowable clearance is .011 inch.**

The internal splines in the rotor (31B) should not show abnormal wear or damage.



Figure HGB-14

## SECTION IV

### ASSEMBLY PROCEDURE

**IMPORTANT:** Before starting assembly, clean all parts with clean petroleum base solvent and air dry. Do not wipe dry with rags. Be sure all dried paint chips have been removed from edges of lapped surfaces. Unless otherwise indicated, do not oil parts before assembly.

1. Reclamp housing (26) in the vise as shown in Figure HGB-9.
2. Assemble thrust washer (14), thrust bearing (13), thrust washer (12) and retaining ring (11) (in that order) on input shaft (17).
3. If the ball retaining spring (25) has been removed, install a new ball retaining spring (25) on valve spool (23). The spring must fit tightly.
4. Insert 5/16" dia. steel ball (24) into ball seat located inside valve spool. (23).
5. Assemble wave washer (15) over thrust washer (14) and thrust bearing (13). Insert the input shaft (17) into the valve spool engaging the helix and 5/16" dia. steel ball with counterclockwise motion. This operation is best done while holding the spool in a horizontal position.
6. Using the midsection of the torsion bar (21) as a gage, insert the gage between the valve spool end and the thrust washer (14). (See Figure HGB-15). This will position the spool in the necessary radial relationship with the input shaft spline teeth for the assembly of the drive ring (19).

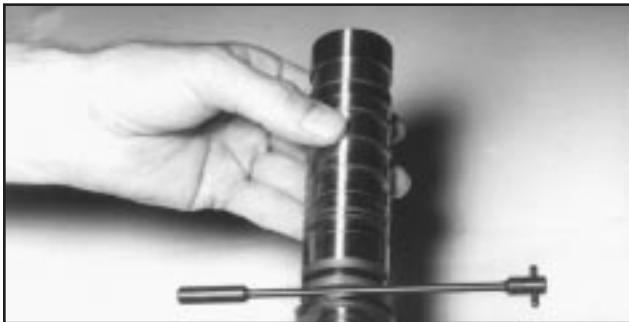

Figure HGB-15

7. Place the input shaft (17) and valve spool (23) assembly in a vertical position with the input shaft end on the table surface.
8. Insert the drive ring (19) into the valve spool (23) end by visually aligning an internal space on the drive ring with a tooth on the input shaft (17) spline and allow drive ring to drop to the limit of its travel. If the drive ring does not engage the input shaft spline, a slight rotation

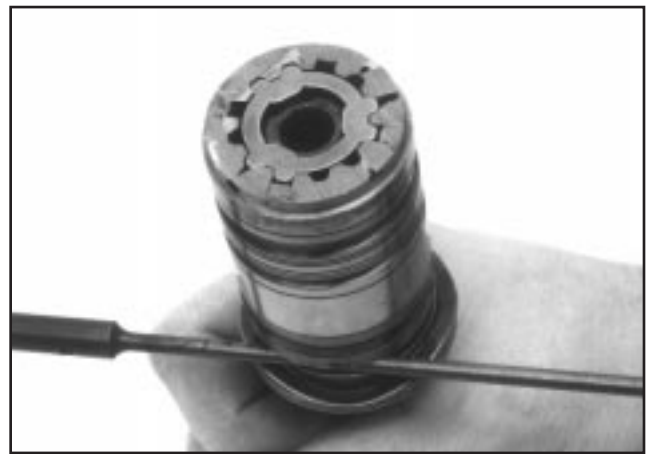

Figure HGB-15A

of the input shaft will allow the drive ring to become fully engaged. Remove the torsion bar (21) gage. (See Figure HGB-15A).

**NOTE:** Rotate the input shaft (17) out of the valve spool (23) until input shaft will no longer rotate. There will be a gap of approximately .350 between end of valve spool (23) and thrust washer (14) if the drive ring (19) is assembled properly.

**CAUTION:** The HGB will not operate properly if the correct orientation of spool, drive ring, and input shaft is not obtained.

9. Install spacer (20) over torsion bar (21) and insert the torsion bar into the valve spool (23).
10. Align the cross-hole in the torsion bar (21) with the cross-hole in the input shaft (17) and insert a .120 diameter pin punch to maintain alignment.
11. Insert needle roller (18) into cross-hole in input shaft (17) and while retracting the pin punch, engage the needle roller in the torsion bar (21) cross-hole.
12. Initiate press of needle roller (18) into torsion bar (21) with a few light impacts. Press needle roller flush with outside diameter of input shaft (17) using a 1/2" drive socket of 11/16" size for supporting the input shaft. (See Figure HGB-16). With a few light impacts on .120 diameter pin punch, drive needle roller (18) approximately 1/32 below the input shaft (17) outside diameter. (See HGB-10).



Figure HGB-16

13a. Assemble spacer (16) over valve spool end of input shaft and valve spool assembly. If spacer (16) has an inside lip on one end, the inside lip end must be against the wave washer (15) when spacer (16) is assembled.

13b. Place assembly, spool end first, into housing (26).

**NOTE: Avoid applying side forces to the valve spool which could cause binding of the closely fitted assembly.**

**NOTE: If neither the input shaft (17) or upper cover (8) are replaced the original shims (10) may be reused. However, if in the inspection of parts, damage is found to the shims, discard these shims and replace with new parts of equal thickness.**

14a. Place shims on top of the thrust washer (12). Coat seal (9) with clean grease and place in upper cover (8) counter-bore. Assemble upper cover onto input shaft (17) and rotate to align punch marks previously made during disassembly.



Figure HGB-17

**NOTE: If a new upper cover (8) is used, no angular orientation is required. However, it is necessary to align the upper cover (8) and housing (26) if both parts are reused.**

Replace upper cover screws (7) finger tight. Assemble pilot ring tool (See Figure HGB-13, page 12) over upper cover (8) (See Figures HGB-17 and HGB-18). Assemble worm drive type hose clamp over pilot ring tool and pilot on housing (26) (See Figures HGB-17 and HGB-18). Tighten hose clamp to align upper cover with housing. Now torque the four upper cover screws (7) to 18-22 ft. lbs.

**NOTE: If the input shaft (17), housing and**

**spool, torsion bar or upper cover (8) have been replaced, the following procedure for checking and shim adjustment must be used.**

14b. Re-assemble as in "14a" above using the required new parts. After torquing the four upper cover screws (7), revolve unit in vise so that the input shaft is pointing downward. In order to determine that the unit is shimmed correctly, the drive link (30) must be in its proper position. To do this, grasp the input shaft (17), pull downward, to prevent rotation. Engage drive link splines in valve spool (23) and rotate to position valve spool essentially flush with end of housing (26). Remove drive link (30) and orient drive link slot to engage needle roller (22) and insert drive link (30). Observe relationship of valve spool (23) end to housing (26) step. If this is within .0025 of being flush, no additional shimming is required. (See Figure HGB-19). If not within .0025, add or remove shims (10) until this requirement is satisfied repeating assembly steps as outlined in "14a" above. (See Figure HGB-19).



Figure HGB-18

14c. The correct shimming must be checked on the vehicle or on a suitable hydraulic test stand. The amount of steering effort required to steer the vehicle when the vehicle is at rest on dry pavement must be equal within two inch pounds. For example: if fifteen inch pounds is required to steer to the right, not less than thirteen or more than seventeen inch pounds should be required to steer to the left.

If a test stand is available to place a load between cylinder ports in the same manner as on the vehicle, a test stand may be used. **Add shims to increase steering efforts in a left turn, subtract shims to increase steering effort in a right turn.**

15. With drive link (30) installed as described above, install new seal (28). Install 13/16" dia.

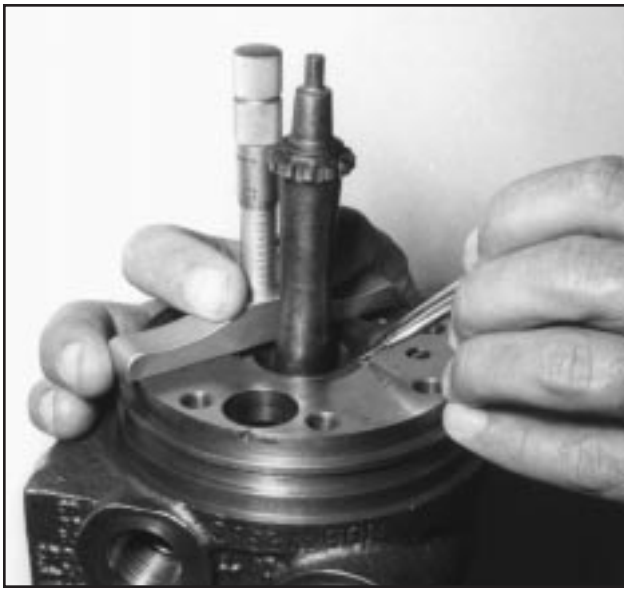

Figure HGB-19

steel ball (27) into housing. (See Figure HGB-8).

16. Screw the two assembly posts into the housing as shown in Figure HGB-20. These assembly posts can be made by simply cutting the heads off of two screws similar to the end cover screws (38).
17. Install wear plate (29), rotor set (31), manifold (32) and commutator ring (33) over the assembly posts. (See Figure HGB-20). **NOTE: The rotor spines are positioned toward the commutator end.**
18. Apply a small amount of clean grease to the inside of each end of sleeve (35) and to the exposed area of seal (28) previously assembled on housing (26).

Assemble the sleeve (35) over the HGB unit and place it on top of seal (28) and housing (26) in a non-cocked position. Assemble end cover assembly (37) onto sleeve (35). Assemble five of the end cover screws (38) into the HGB unit finger tight. Alternately and progressively, snug up the end cover screws to draw the sleeve down into its proper position over seal (28). Remove five end cover screws (38). Remove end cover assembly (37).

19. Assemble new seal (28) on small diameter of end cover assembly (37).
20. Apply a small amount of clean grease to the washer (36) and install it over the pin in the end cover assembly (37). The grease should adhere the washer to the end cover assembly.
21. Apply a small amount of clean grease to commutator (34) and install it over the pin in the end cover assembly (37) and on top of washer (36). The grease should adhere the commutator to the end cover assembly. **The commutator (34)**

**must be assembled with the countersink side against the washer (36).**

22. Position the end cover assembly (37) with commutator (34), washer (36) and seal (28) in place as shown in Figure HGB-21.

**NOTE: The relationship of the small elongated hole in the commutator (34) to one of the seven holes in the end cover assembly (37) and one of the assembly posts is very important. They must be "in line" as shown in Figure HGB-21.**

23. Turn the input shaft (17) to locate the tip of the drive link (30) in a position so that it will accept the elongated hole in the commutator (34).

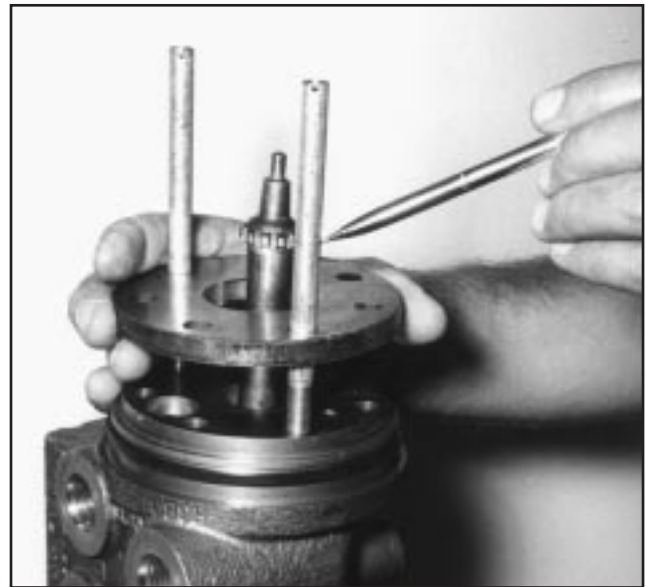

Figure HGB-20



Figure HGB-21



24. Apply a generous amount of clean grease to seal (28) assembled previously on end cover assembly (37). Carefully turn the end cover assembly (37) over and onto the assembly posts. Place the end cover assembly on top of the sleeve in a non-cocked position. **Do Not Attempt** to press end cover assembly down into place.
25. Install five end cover screws (38) finger tight. Remove the two assembly posts and install other two end cover screws (38) finger tight. Alternately and progressively, snug up end cover assembly down into place. Finish tightening end cover screws to 45-55 ft. lbs. torque. **NOTE: Rotate the input shaft during final torque procedure to prevent binding.**
26. Relocate HGB Unit in vise with input shaft (17) up and install new seal ring (6) onto input shaft.
27. Note: Cover the end of the Hydraguide unit input shaft with cellophane tape to protect the new seal (5) when it is assembled over the sharp edges of the input shaft.  
Lubricate the new seal using hydraulic oil and install the new seal (5) with lip side first, on to the Hydraguide unit input shaft (17).  
**NOTE: Seal (5) and seal ring (6) may be bonded together as a single unit. Lubricate and install new seal with lip side first onto input shaft.**
28. Assemble new spacer (4) with small end first, onto input shaft (17) and push new spacer (4), new seal ring (6) and new seal (5), previously installed, down into upper cover (8) seal bore. (A short piece of metal tubing, 15/16 minimum I.D. x 1-3/16 maximum O.D. or a 7/8 deep well socket may be used to push these parts into place.
29. Assemble retaining ring (3) onto input shaft (17) and down into upper cover (8) groove. Be sure the rounded edge of the retaining ring (3) is faced inward.
30. Assemble new seal (2) onto input shaft (17) and down into upper cover (8) counterbore.  
**NOTE: if the unit is to be stored, plug the cylinder ports and fill the inlet port with clean oil. Rotate input shaft until oil appears at port.**
31. Replug the port holes to prevent entrance of dirt. This completes assembly of the HGB unit.

### FILLING AIR BLEEDING THE SYSTEM WHEN DRAINED OF OIL

1. Fill reservoir nearly full. Be ready to add oil when the engine is started. Do not let oil level drop below the inlet to the power pump so that the power pump will not suck air into the system.
2. Start engine and let it idle. Immediately add oil to the reservoir as needed.

**NOTE: This oil will now be circulating only from the power pump to and through part of**

### the HGB control valve and to the reservoir and back to the power pump.

When no more oil can be added and oil is clear, proceed as follows.

3. With one finger on a spoke of the steering wheel, spin wheel as rapidly as possible to bleed the air in the steering cylinder(s) and lines.
  4. Immediately upon HGB valve spool actuation oil must be added to the reservoir — to replenish the oil moving into the circuit.
  5. Keep rotating the steering wheel to keep the HGB valve spool actuated. Do this until the road wheels have reached the stop in that direction, then quickly reverse the steering wheel rotation to actuate the HGB valve spool in the opposite direction.
  6. Keep rotating the steering wheel left and right from stop to stop of the road wheels to bleed out air. Replenish oil as necessary.
  7. The air will bleed out only at the reservoir, therefore, the oil must be circulated in both directions repeatedly until the air has bled out.  
**NOTE: The oil in the lines to the power cylinder reaches a “dead end” at the piston. The oil in the cylinder does not flow in a circuit. As the piston moves back and forth the oil moves back and forth in the lines. Therefore, air in these lines and the cylinder may be slow moving into the HGB control valve and to the reservoir.**
- CAUTION: Do not operate vehicle until air is bled out.**
8. When the oil in the reservoir is clear (not cloudy or creamy), the system is free of air. (Slight creep or drift of the steering wheel is normal.)
  9. Adjust the oil to recommended level in reservoir and assemble reservoir cover.
  10. Always fill reservoir to recommended level.

### HYDRAULIC FLUID

Keep the steering system filled with one of the following:

Automatic Transmission Fluid Type “F”

Automatic Transmission Fluid Dexron II

Hydraulic fluid as recommended by the vehicle manufacturer.

**WARNING: DO NOT MIX OIL TYPES, ANY MIXTURE, OR AN UNAPPROVED OIL, COULD DETERIORATE THE SEALS. ENOUGH FLUID COULD THEN LEAK TO CREATE A LOSS OF POWER STEERING ASSIST. DO NOT ALLOW FLUID LEVEL TO GO BELOW FILL LINE ON DIPSTICK. BEFORE ADDING NEW FLUID, COMPLETELY DRAIN OLD OIL FROM THE SYSTEM. IT MAY BE NECESSARY ALSO THAT YOU FLUSH THE SYSTEM WITH CLEAN OIL.**

# HGB COLUMN

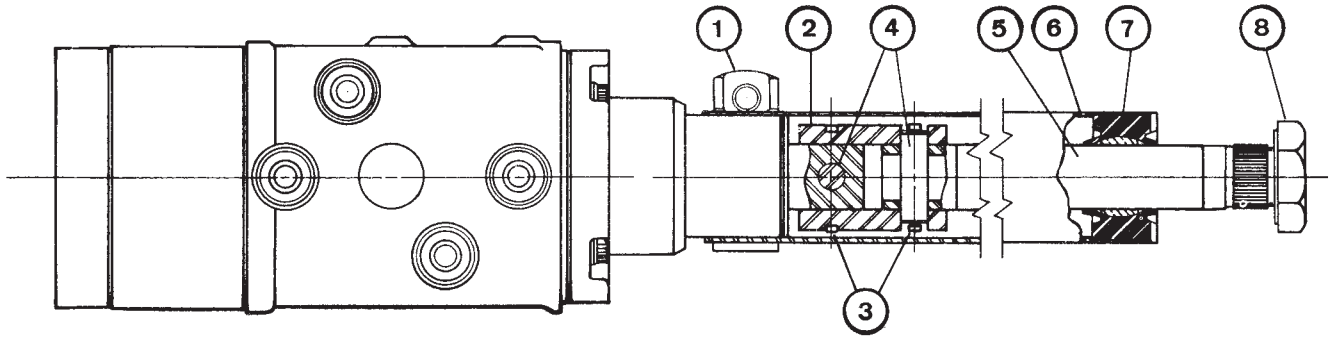

1.	475109-A1	4.	040050	7.	063980
2.	403813	5.	089142	8.	026045
3.	401362	6.	096245	6. & 7.	096245-A1

## TO DISASSEMBLE COLUMN

1. Remove steering wheel and wheel nut (8).
2. Loosen clamp assembly (1) on upper cover of HGB unit. If the application has a column support clamp, this clamp should be loosened at this time.
3. If there is a horn contact assembly on the column, remove the 4 small screws from the metal cover (if applicable), and remove the metal cover and gasket. Remove the 2 small screws from the horn contact assembly.
4. Pull the jacket tube (6) and bearing assembly (7) off of the wheel tube (5).
5. Remove the retaining springs (3).
6. Lightly tap out the pins (4) with brass rods and hammer. Do not hit the pins with heavy hammer blows, as this may damage the needle bearing in the HGB unit.
7. Remove the wheel tube (5).
8. Remove the coupling (2).
9. Remove the clamp assembly (1).

## TO ASSEMBLE COLUMN

1. Assemble the clamp assembly (1) onto the HGB unit. (Do not tighten.)
2. Assemble the coupling (2) and align pin hole.
3. Assemble one of the pins (4) and one of the retaining rings (3).
4. Assemble the wheel tube (5) and align pin hole.
5. Assemble the other pin (4) and retaining ring (3).
6. Apply a small amount of clean grease to the inside of bearing assembly (7).
7. Assemble the jacket tube (6) and bearing assembly (7) over the wheel tube, through the clamp assembly (1) and onto the HGB unit upper cover.
8. Tighten the clamp assembly (1) bolt to 15-20 ft. lbs.
9. Assemble the steering wheel and tighten the wheel nut to 32.5 - 37.5 ft. lbs.
10. If the application has a column support clamp, it is extremely important that the jacket tube (6) align with this clamp in the free state. If misalignment is evident, the HGB unit must be shimmed at the mounting surface to eliminate the misalignment, or damage may result to the HGB unit.
11. If applicable, assemble the horn contact assembly, cover gasket and metal cover on the jacket tube (6).



## TIPS FOR MAINTAINING THE HYDRO-STATIC STEERING SYSTEM

- Top up fluid level in reservoir as necessary.
- Maintain correctly inflated tires.
- Always use a puller to remove the steering wheel. Do not use a hammer, torch, or crow bar.
- Investigate and correct immediately any play, rattle, shimmy, or other unusual occurrence in the steering system.
- Remove cause of steering column misalignment.
- Encourage all drivers or operators to report any malfunction or accident that may have damaged a steering system part.
- Do not attempt to weld any broken steering

component. Replace the component with original equipment only.

- Do not cold straighten, hot straighten, or bend any steering part.
- Prevent dirt or other foreign matter from entering the hydraulic system. Clean off around filler caps before checking oil level.
- Investigate and correct any external leak in the steering system, no matter how minor the leak.
- Comply with manufacturer's specifications for cleaning or replacing the filter.

## WARNINGS for Proper Steering System Operation

**WARNING:** DO NOT WELD, BRAZE, OR SOLDER ANY STEERING SYSTEM COMPONENT.

**WARNING:** MAXIMUM OPERATING PRESSURE MUST NOT EXCEED VEHICLE MANUFACTURER'S RECOMMENDED PUMP PRESSURE CAPACITY.

**WARNING:** ALWAYS CAREFULLY INSPECT ANY STEERING SYSTEM COMPONENT THAT MAY HAVE BEEN STRUCK OR DAMAGED DURING OPERATION OR IN AN ACCIDENT. REPLACE ANY COMPONENT THAT IS DAMAGED OR THAT IS QUESTIONABLE.

**Ross extends close technical cooperation and assistance. If steering problems occur which you cannot solve, please contact our Ross Field Service Department. Our phone number and address are on the back cover of this manual.**

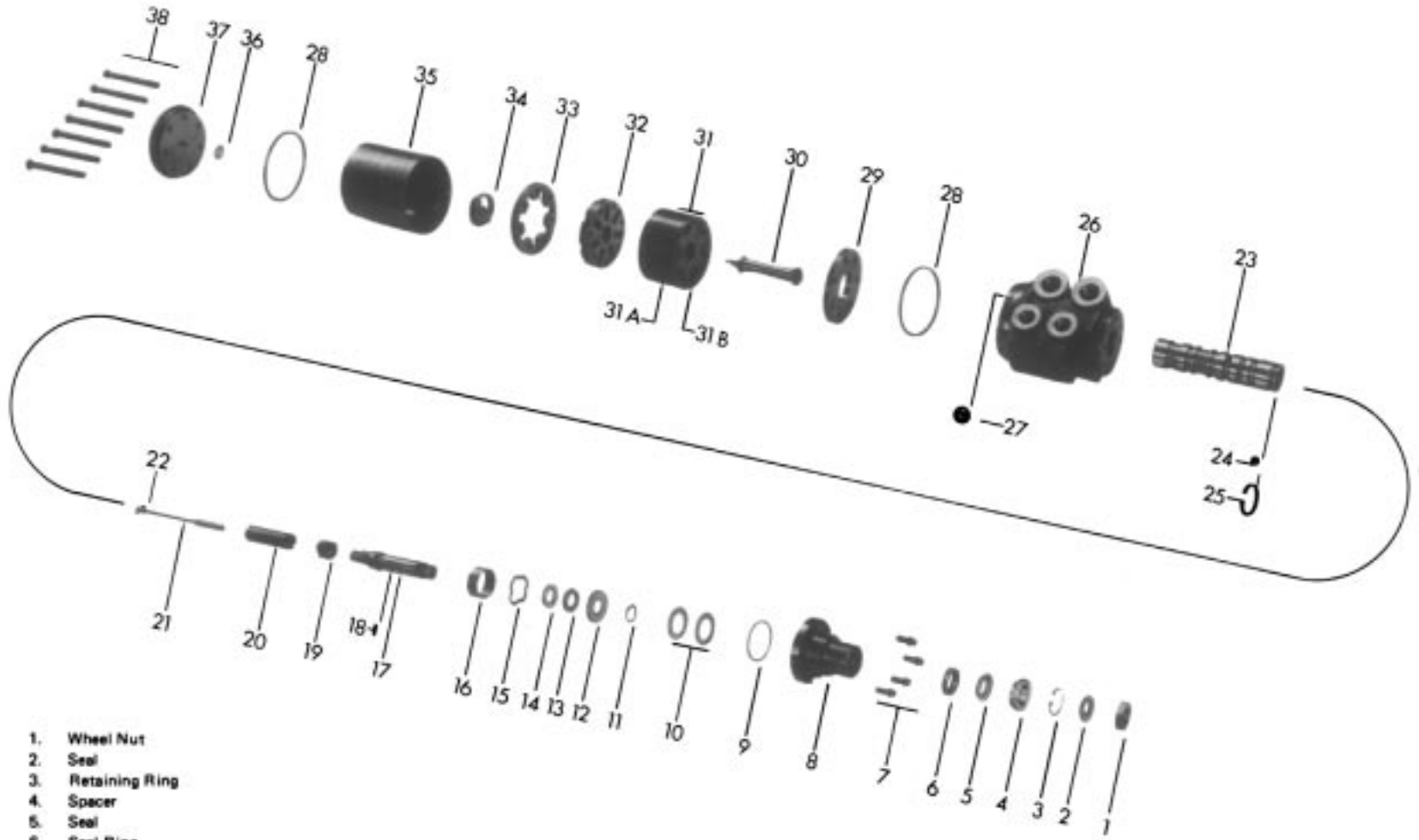

- |                            |                       |                              |
|----------------------------|-----------------------|------------------------------|
| 1. Wheel Nut               | 19. Drive Ring        | 30. Drive Link               |
| 2. Seal                    | 20. Spacer            | 31. Rotor Set                |
| 3. Retaining Ring          | 21. Torsion Bar       | 31A. Stator                  |
| 4. Spacer                  | 22. Needle Roller     | 31B. Rotor                   |
| 5. Seal                    | 23. Valve Spool       | 32. Manifold                 |
| 6. Seal Ring               | 24. Ball (5/16 Dia.)  | 33. Commutator Ring          |
| 7. Screw (5/16-18-3/4) (4) | 25. Spring            | 34. Commutator               |
| 8. Upper Cover             | 26. Housing           | 35. Sleeve                   |
| 9. Seal                    | 27. Ball (13/16 Dia.) | 36. Washer                   |
| 10. Shims                  | 28. Seal (2)          | 37. End Cover Assembly       |
| 11. Retaining Ring         | 29. Wear Plate        | 38. Screw (3/8-24-3 7/8) (7) |
| 12. Thrust Washer          |                       |                              |
| 13. Thrust Bearing         |                       |                              |
| 14. Thrust Washer          |                       |                              |
| 15. Wave Washer            |                       |                              |
| 16. Spacer                 |                       |                              |
| 17. Input Shaft            |                       |                              |
| 18. Needle Roller          |                       |                              |

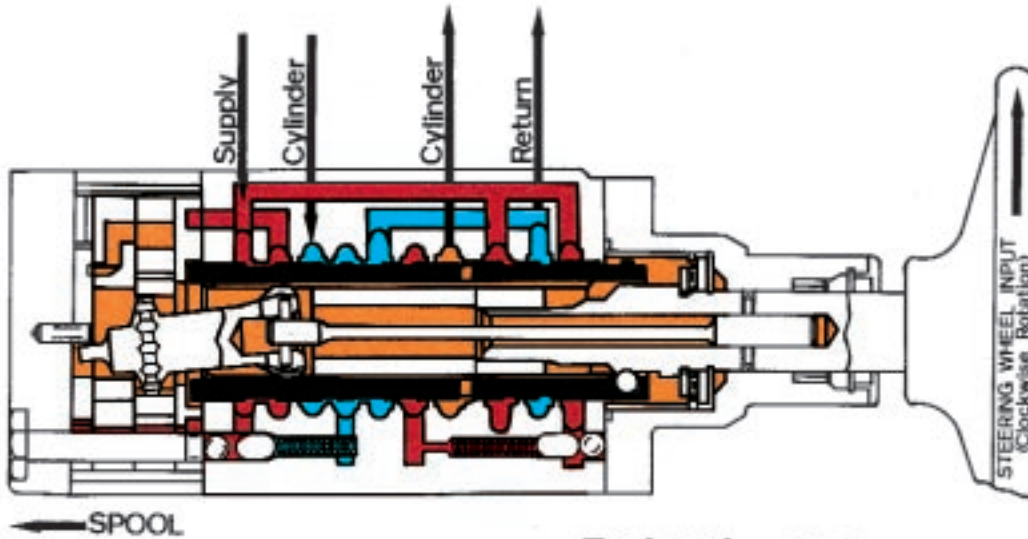

**Right Hand Turn**

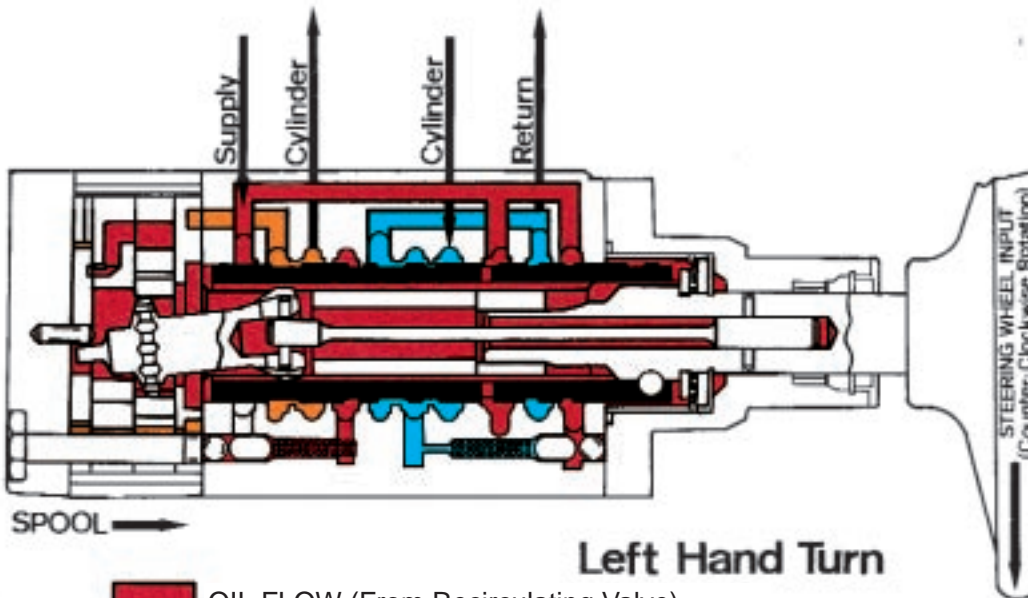

**Left Hand Turn**

- OIL FLOW (From Recirculating Valve)
- RETURN OIL (To Recirculating Valve)
- METERED OIL FLOW (To Cylinder)

# HGB Service Manual



Ross Operation  
2745 Snapps Ferry Road  
Greeneville, TN 37745 USA  
Tel: (423) 639-8151  
Fax: (423) 787-2418 (Sales)